

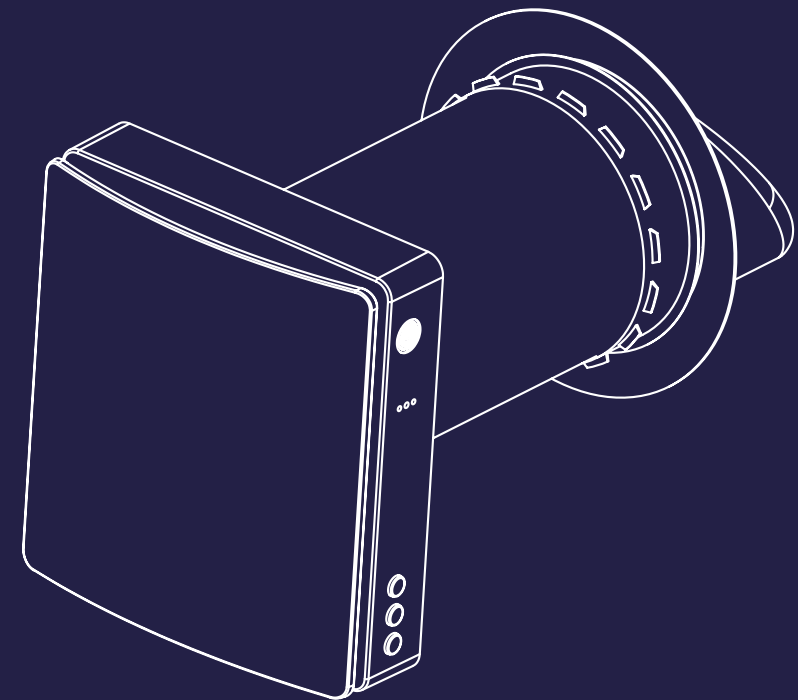

NP-TTW5-W

Nova Residence Single Room
Energy Recovery Ventilator
Instruction Manual



Nova Projects Development

Address: Tunari, Str. Codrului nr.1 birou 1

Tel: +40 724 083 620

Website: www.villanova.ro

Website: www.novaprojects.ro

01000000608
AP06K01501



Content

SAFETY REQUIREMENTS	3
INTRODUCTION	5
USE	6
PACKING LIST	6
MAIN TECHNICAL PARAMETERS	7
DESIGN AND OPERATION	8
INSTALLATION DRAWING	9
OPERATION MODES	10
VENTILATOR INSTALLATION	11
FUNCTION DESCRIPTION	14
REMOTE CONTROLLER	15
PAIRING SYNCHRONIZATION FUNCTION	16
MASTER UNIT SETTINGS	17
SLAVE UNIT SETTINGS	18
MASTER AND SLAVE UNITS RESET AND CANCELLATION	18
IOT NETWORKING FEATURES	19
IOT NETWORKING OPERATION STEPS	21
MAINTENANCE	23
STORAGE AND TRANSPORTATION RULES	24
TROUBLESHOOTING	25

► SAFETY REQUIREMENTS

- Read the user's manual carefully before operation and installation of the heat recovery ventilator NP-TTW5-W.
- Installation and operation of the ventilator shall be performed in accordance with the present user's manual as well as the provisions of all the applicable local and national construction, electrical and technical codes and standards.
- The warnings contained in the present user's manual must be considered seriously since they contain vital personal safety information.
- Failure to follow the safety instructions may result in personal injury or ventilator damage.
- Read the manual carefully and keep it as long as you use the ventilator.
- This appliance can be used by children aged from 8 years and above and persons with reduced physical, sensory or mental capabilities or lack of experience and knowledge if they have been given supervision or instruction concerning the use of the appliance in a safe way and understand the hazards involved.
- Don't allow children to play with the appliance.
- Don't allow children to clean and maintain without supervision.
- If the power cord is damaged, it must be replaced by the manufacturer or its service agent or similarly qualified person in order to avoid a hazard.
- It's suggested to install the ventilator more than 2.1 m above the floor.
- Precautions must be taken to prevent the back-flow of gases into the room from the open flue of gas or other fuel-burning appliances.
- Exhaust fans may adversely affect the safe operation of appliances burning gas or other fuels (including those in other rooms) by the backflow of combustion gases. These gases may cause carbon monoxide poisoning. After installation of an exhaust fan such as a partition fan or a duct fan the operation of an open flue gas appliances should be tested by a competent person to ensure that backflow of combustion gases does not occur.
- Don't recharge non-rechargeable batteries.
- Batteries must be inserted with the correct polarity.
- Remove used batteries from the appliance and safely disposed of.
- If the appliance is to be stored unused for a long period, the batteries should be removed.
- Don't short-circuit the power supply terminals.
- Take good care of the remote control to prevent children from swallowing batteries and cause accidents.





Symbol Used In The Manual

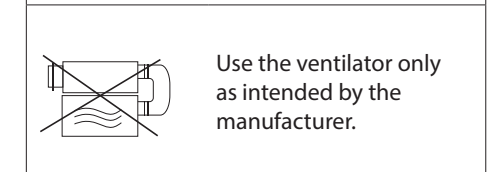
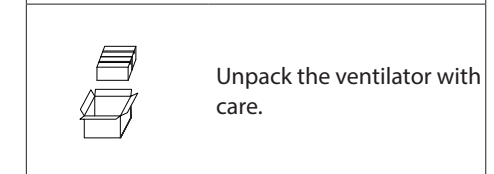
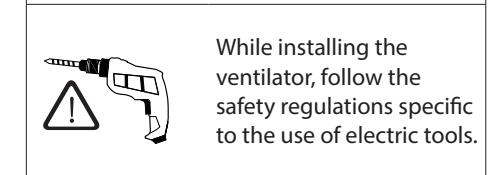
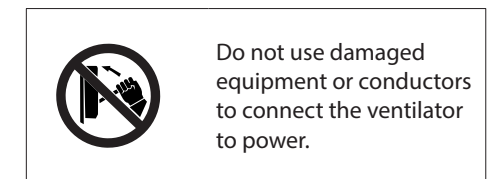
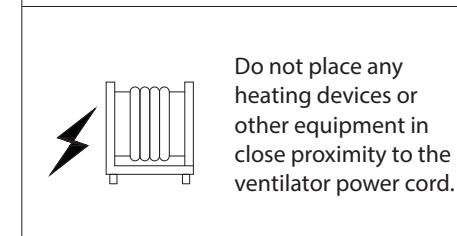
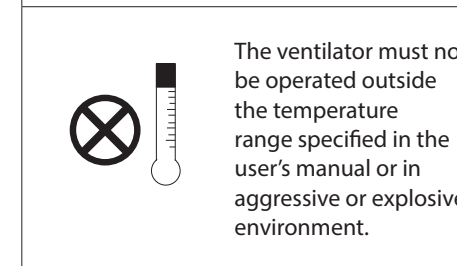
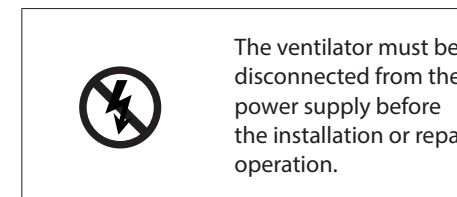

Ventilator Installation Safety Precautions

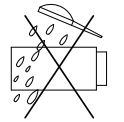
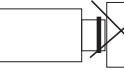
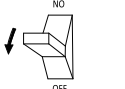
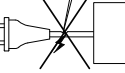
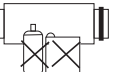
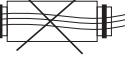

Ventilator Installation Safety Precautions

	Do not touch the controller or the remote control with wet hands. Do not carry out the ventilator maintenance with wet hands.
	Do not allow children operate the ventilator.
	Do not clean the ventilator with water. Protect the electric parts from water ingress.
	Do not block the air duct when the ventilator is on.
	Disconnect the ventilator from the power supply before maintenance.
	Do not damage the power cable while operating the ventilator. Do not put any objects on the power cable.
	Keep explosive and inflammable products away from the ventilator.
	Do not open the operating ventilator.
	Do not direct airflow from the ventilator onto the open flames or candles.

► INTRODUCTION

This user's manual includes technical description operation, installation and mounting guidelines, technical data for the heat recovery ventilator NP-TTW5-W.

► USE

- The ventilator is designed to exchange air in apartments, villas, hotels, cafes, and other domestic and public buildings. The ventilator is equipped with a ceramic energy regenerator and a fan that supplies fresh air and extracts air with energy recovery.
- The ventilator is designed for through the wall mounting. The telescopic design of the fan allows its installation in walls from 280 mm to 470mm thick.
- The ventilator is designed for continuous operation always connected to power supply.
- The transported air must not contain any flammable or explosive mixtures, evaporation of chemicals, coarse dust, soot and oil particles, sticky substances, fibrous materials, pathogens, or any other harmful substances.



INSTALLATION AND CONNECTION OPERATIONS MUST BE PERFORMED ONLY BY PROPERLY QUALIFIED PERSONNEL AFTER THE APPROPRIATE SAFETY BRIEFING.

THE VENTILATOR INSTALLATION SITES MUST PREVENT ACCESS BY UNATTENDED CHILDREN.

► PACKING LIST

Ventilator	1 pc
Accessories bag	1 pc
Remote controller	1 pc
User's manual	1 pc
Packing box	1 pc

► MAIN TECHNICAL PARAMETERS

- The ventilator is designed for indoor application with an ambient temperature ranging from -20°C (-4°F) to +50°C (+122°F) and relative humidity below 80%.
- The ventilator is classified as a class II electric appliance.
- Ingress Protection (IP) rating is IPX4.
- The ventilator design is subject to continuous improvement, so some models may differ slightly from the models described in this manual.

Ventilator Overall Dimensions (mm)

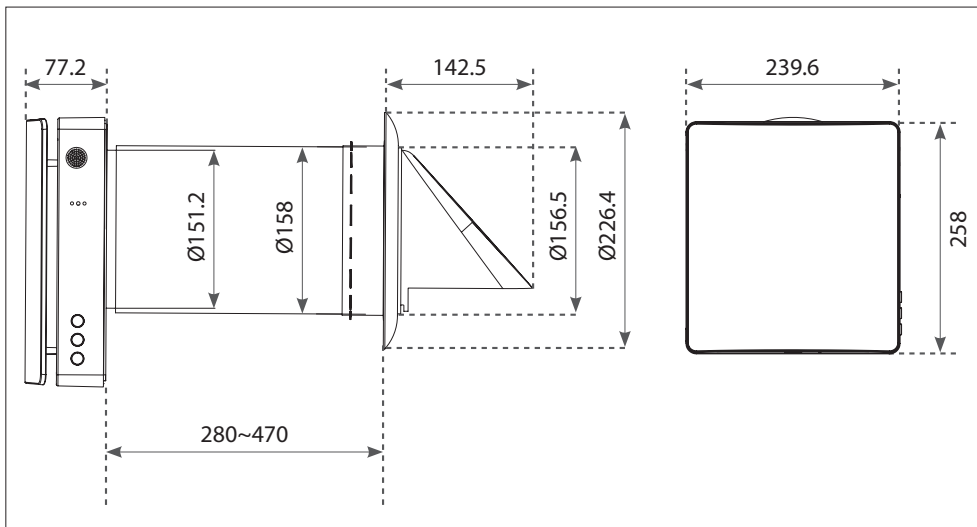

Description	Unit	Value
Voltage	V	100-240
Frequency	Hz	50/60
Input Power	W	6/7/7.8
Current	A	0.04/0.05/0.06
RPM	-	1000/1550/1800
RPM (max)	-	2200
Airflow (L/M/H) in supply/exhaust mode (with F7 filter)*	m ³ /h	20/40/50
Airflow (L/M/H) in regeneration mode (with F7 filter)*	m ³ /h	10/20/25
Airflow in supply/exhaust mode (with F7 filter)*	CFM	11.8/23.5/29.4
Airflow in regenerator mode (with F7 filter)*	CFM	5.9/11.8/15
Max airflow (under fan boost mode)	m ³ /h	60
Max airflow (under fan boost mode)	CFM	35
Sound Pressure Level	dB(A)	32.7
Heat Recovery Efficiency	%	up to 97
Ingress Protection Rating	-	IPX4
Air Duct Diameter	mm	158
SEC	-	Class A
Mounting Type	-	Wall Mounting
Net Weight	kg	4.2

*Note: The airflow in supply/exhaust mode without F7 filter is about 34/56/70 CMH or 20/33/41.2 CFM, and the relative parameters will be adjusted accordingly.

► DESIGN AND OPERATION

- The ventilator consists of a telescopic air duct with adjustable length regulated by the position of the inner air duct inside the outer air duct, the ventilation unit, and the ventilation hood.
- F7 filter+prefilter and the ceramic energy regenerator are located inside the inner duct. The filters are designed to purify supply air and prevent foreign objects from ingress into the regenerator and the fan.
- The ceramic energy regenerator extracts energy from exhaust air to warm up or cool down supply air.
- The regenerator is equipped with a pull cord inside to facilitate its withdrawal from the ventilator. The regenerator is installed on an insulation material which is used as a sealant as well.
- The ventilator is available to be installed from the inner side of the wall.

► **INSTALLATION DRAWING**

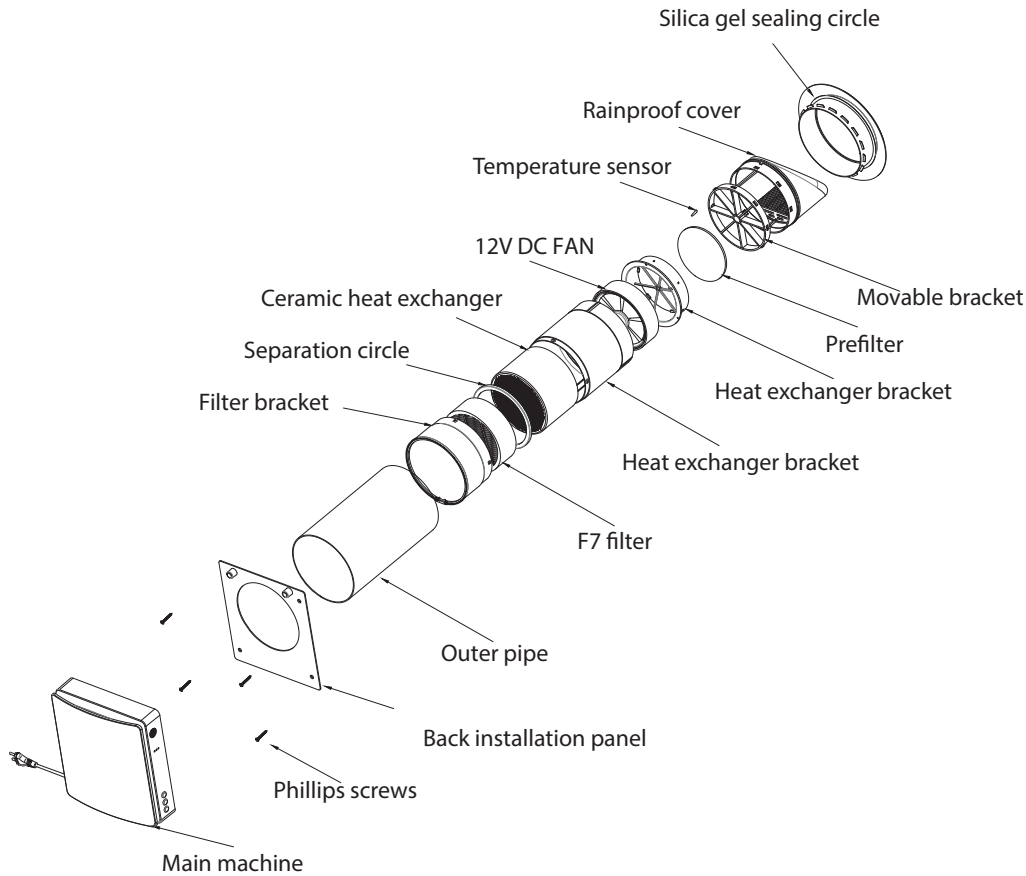

► **OPERATION MODES**

Ventilation Mode. The ventilator runs in exhaust or supply mode at a set speed. When synchronous operation of two connected ventilators, one runs in the supply mode and the other in exhaust mode.

Regeneration Mode. The ventilator runs in two cycles of 75 seconds each, to provide heat and moisture regeneration.

Interval 1 The warm polluted air is extracted from the room and goes through the ceramic regenerator, which gradually absorbs heat and moisture. After 75 seconds the ventilator switch to air supply mode.

Interval 2 The fresh and cold outdoor air goes through the heat regenerator and absorbs the accumulated moisture and heat after 75 seconds, when the energy regenerator gets cold, the ventilator switches to the exhaust mode.

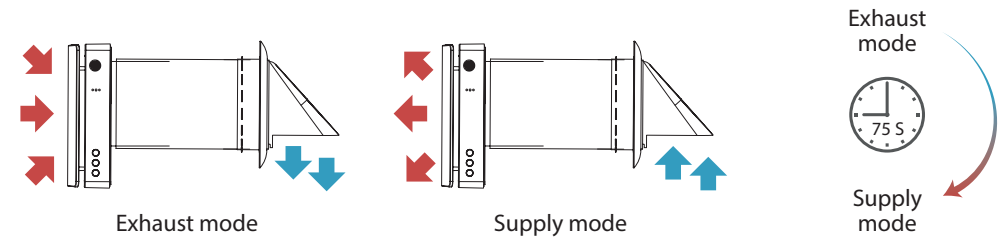

CAUTION!

INSTALLATION AND SET-UP

Read The User's Manual Before Installation The Ventilator

To prevent room dust deposition and accumulation, the ventilator must not be installed in places where the air duct may be blocked by the blinds, curtains, drapes, etc. Meanwhile, curtains might obstruct normal airflow in the room, making ventilator operation inefficient.

► VENTILATOR INSTALLATION

1. Drill a 170 mm round hole in the wall. The hole size is shown below.

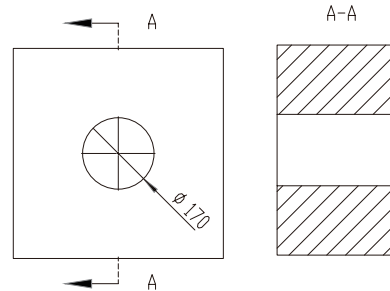

Assemble the inner duct and outer duct together to adapt to the thickness of the wall, then take out the inner duct and put the outer duct into the wall hole. After that, grasp the bracket to spin the outer duct forward and backward, left and right to make the air inlet/outlet correctly placed downward by the sign of the external ventilation hood. (The outer duct shall not be longer than the wall thickness, and the extra parts can be removed. Installation of outer ducts with/without accessories, please refer to step 5)

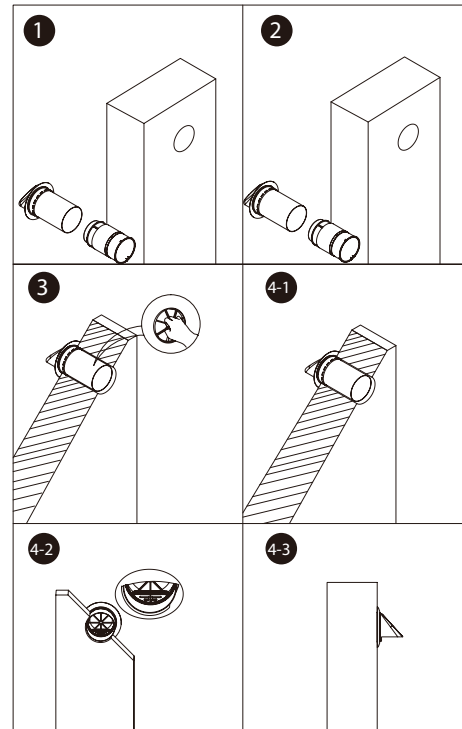

2. Pull the mobile bracket into the outer duct back into place so that the silicone ring on the outside of the outer duct is tight against the outer wall.

Fill the space between the wall and the outer duct with the PU glue provided in the kit before attaching the back cover mounting plate, and then wait for the glue to dry.

Then install the back cover mounting plate, align the round hole of the back cover the mounting plate with the round hole on the wall, and measure the level of the mounting plate with a level ruler to ensure that the mounting plate installation is horizontal, then mark the hole, punch in the expansion rubber grain, then align the mounting plate with the hole and fixing it with a screw.

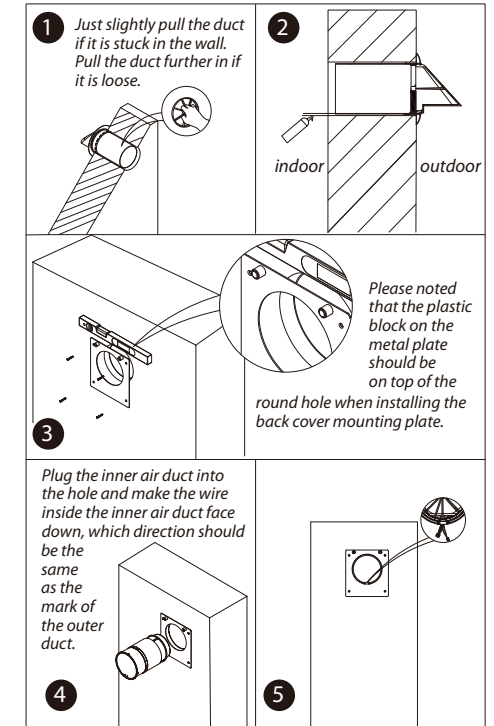

- Install the main unit on the indoor surface wall, and connect the adapter wire from the back of the main unit to the wiring of the fan and temperature sensor exposed by the inner duct in the wall. Tidy the wiring, align the main unit with the plastic block protruding on the back cover board and install it in. (There are corresponding concave holes on the back of the main unit.) Just install it, no other operations are required. The back of the main unit is equipped with a strong magnet, which will automatically attract the mounting plate on the wall (After installation, please check that if there is a large gap between the main unit and the mounting plate. If yes, it means that the wires in the main unit are not sorted out. Therefore, please remove the main unit and reinstall it)

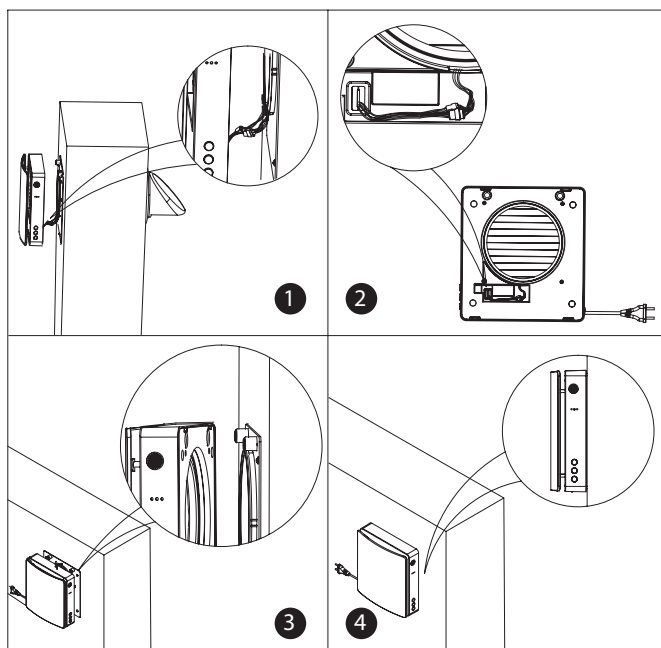

► FUNCTION DESCRIPTION

Description Of The Master Unit

Master unit front

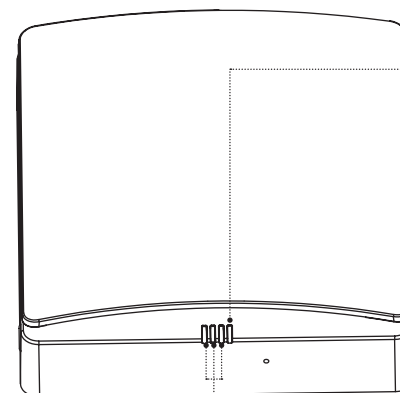

Function Light (RGB-LED)

- Function light indicates the fan speed, 3 speeds in total.
- The green light indicates air supply.
- The red shows as air exhaust.
- The blue shows as the regeneration mode, which switches after 75 seconds of cyclic operation between air supply and air exhaust.

Status Light (RGB-LED)

ON status

- Blue light is on: Pairing mode is activated, and the linkage communication function is realized between the master and slave units.
- Green light is on: IoT function is enabled, WIFI is connected successfully, and it's available to control the device from the phone.
- Red light is on: Filter cleaning alarm to remind that it is time to clean or replace the filter in the inner duct.
- Purple light is on: Indicates the master role in master-slave online mode, and the master lot networking function is enabled, and the unit can be controlled by the phone.
- Green light flashes slowly: Automatic ventilation function is on and running.
- Blue light flashes slowly: Free-cooling function is on and running.
- Red light flashes three times: Indicates that the filter cleaning is completed and the cleaning time is reset.

OFF status (coordinate with the buttons)

- Blue light flashes slowly: Indicates the device role set as the master in pairing mode.
- Green light flashes slowly: Indicates the role of the device set as a slave in pairing mode.
- Red light flashes slowly: Indicates that the device is in WIFI connection mode.

Master unit side

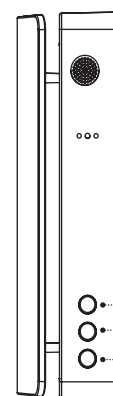

MODE

ON state: you can switch the working mode of the device (supply mode, exhaust mode, regeneration mode).

FAN SPEED

ON state: you can switch the fan speed of the device, 3 speeds in total.

ON/OFF

Control the device to an ON/OFF state.



CONNECTION TO POWER

DISCONNECT THE VENTILATION FROM THE POWER SUPPLY TO ANY ELECTRIC INSTALLATION OPERATIONS.

THE VENTILATOR IS DESIGNED FOR CONNECTION TO SINGLE-PHASE AC100-240 V/50-60 HZ POWER SUPPLY. CONNECT THE VENTILATOR TO THE SOCKET DIRECTLY.

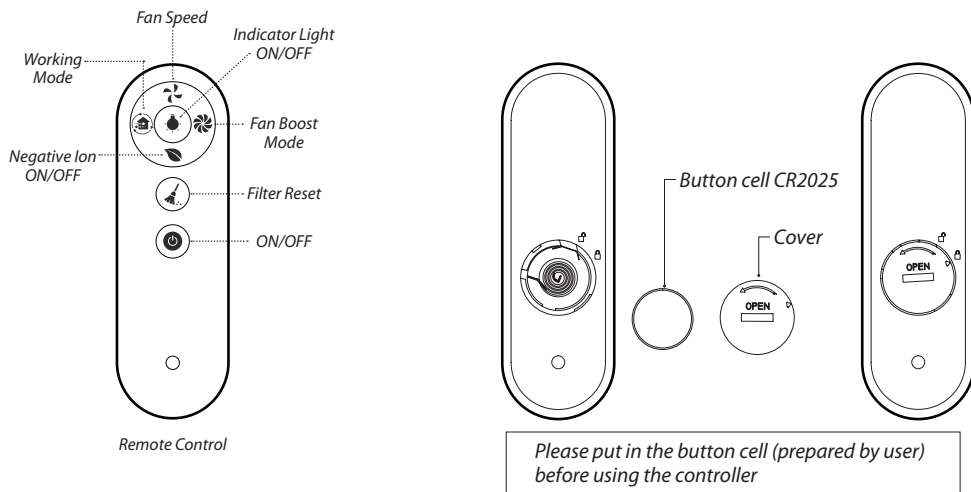

Remote Controller

- Fan Speed:** switch the fan speed of the device, 3 speeds in total.
- Working Mode:** switch the working mode of the device (supply mode, exhaust mode, regeneration mode).
- Negative Ion ON/OFF:** Negative ion generator power socket work switch, (when the negative ion function is turned on, the device supplies air when the power supply, negative ion generator needs to be purchased separately and loaded)
- Indicator Light:** Control indicator light on and off.
- Fan Boost Mode:** Set the fan into the fan boost mode, and the fan runs at maximum power if there is no other setting, the device runs for 30 minutes to turn off this mode automatically.
- Filter Reset:** After replacing the filter of the inner air duct, long press the button for 5 seconds, the device red light flashes three times, and the filter cleaning time reset. (Reset time default 720 hours)
- ON/OFF:** Turn ON/OFF the device.

This remote control uses infrared signals.

- Before using the remote control, inset the battery into the remote control and screw the battery cover tightly
- After inserting the battery, screw the battery cover clockwise as shown until the cover triangle arrow indicates the locking pattern, which means it is locked (please do not tighten the cover with your bare hands to avoid damage to your hands)
- To remove the battery, turn the battery cover counterclockwise as shown in the picture until the triangle arrow of the cover indicates the unlocking pattern, that is, loose, then the battery can be removed
- Please store the remote control properly to prevent children from swallowing the batteries and causing accidents.

► PAIRING SYNCHRONIZATION FUNCTION

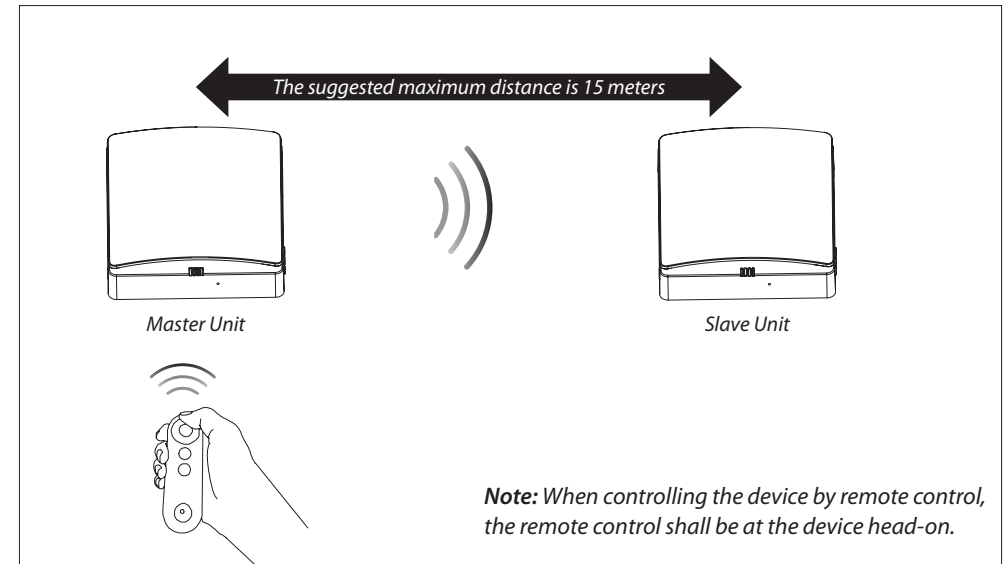

- Without setting a master/slave role, one remote control can control one or more devices.
- After setting the master/slave role, the current use of the remote control can only control the master, and the master will send the synchronization signal to the slave (the slave does not receive the remote control signal), so that the slave mode is synchronized with the master. (The master can only control one slave alone).
- In regeneration mode, the operation direction of the slave fan is opposite to that of the master, and the direction of the slave fan in other modes is the same as that of the master.
 - The maximum linear unobstructed communication signal distance between master and slave is 15m.
 - The signal from the master and slave can pass through a 180mm thick brick wall.

► MASTER-SLAVE UNIT SETTINGS

Master Unit Settings

Connect the device with power. In the OFF state, as shown in the figure, long press the fan speed button of the unit for 5 seconds, and the status indicator blue light flashes slowly. At this time, the device enters the master-slave linkage mode, it is set to the master role.

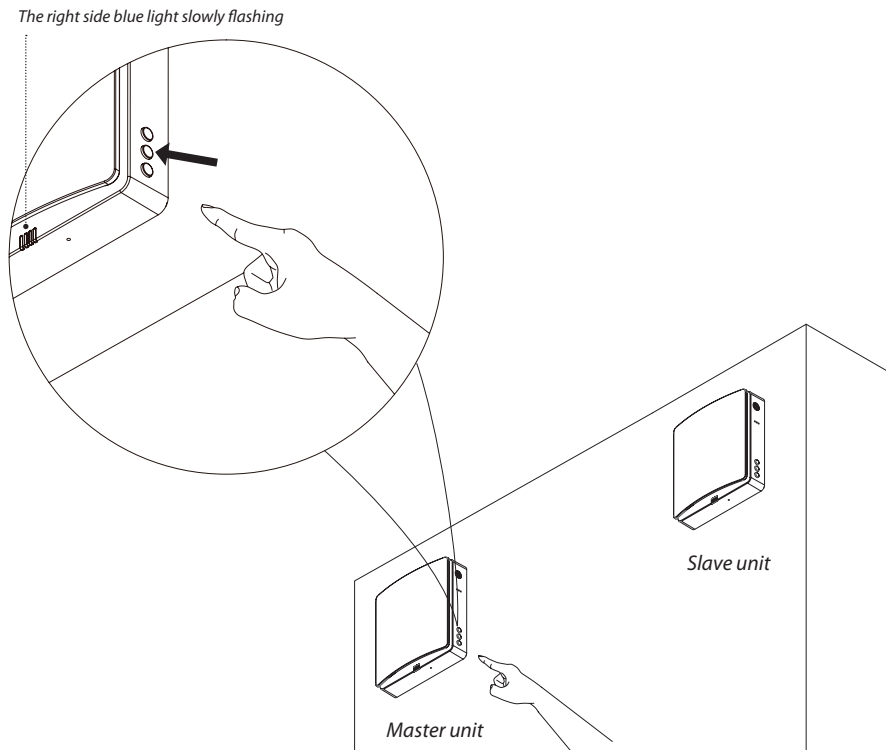

Slave Unit Settings

1. Connect the device to power. In the OFF state, as shown in the figure, long press the mode button of the device for 5 seconds, and the status indicator green light flashes slowly. At this time, the device enters the master-slave linkage mode, the unit is set to the slave role.
2. During the master and slave set pairing mode, it should be carried out at the same time for a limited time (within 1 minute). The devices should be as close as possible, the device will be automatically connected.
3. The status light of the paired devices will change to blue light ON to indicate that master-slave pairing is successful.
4. If the master-slave pairing fails, the status lights on the devices will flash for one minute and then light-off automatically.

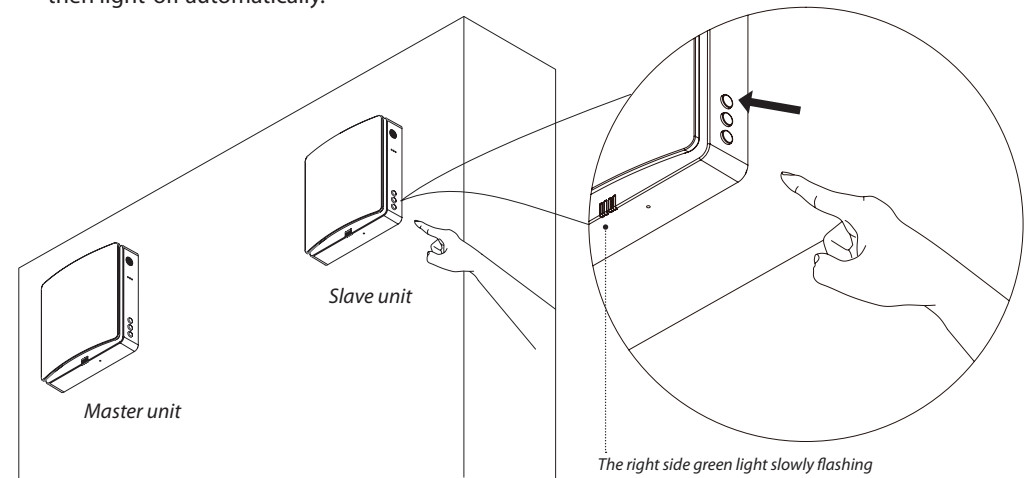

► MASTER-SLAVE RESET AND CANCELLATION

Connect the device with power. In the OFF state, long press the fan speed button of the linked device for 5 seconds, and the device status indicator blue light flashes slowly. At this time, the linked device enters the master-slave linkage mode, the device definition is the master role. It should be carried out at the same time for a limited time (within 1 minute), and wait for the status indicator lighting off automatically, then the device is not connected to the slave to break off the master-slave pairing automatically as well. At this stage, the device is reset and restored to the factory state, without any role definition.

► IOT NETWORKING FUNCTIONS

CO₂ Version

ERV name. The app can connect multiple devices. Each device will have a different name, and user can change the device name freely.

Pairing icon. After the devices are paired, the icon is displayed, and the slave is offline and can't be operated.

Filter alarm. It reminds the user to clean or replace the filters. Icon disappears after reset.

CO₂ concentration setting. When the CO₂ sensor is connected, if the indoor CO₂ concentration exceeds the set value while the unit is operating in regeneration mode, the unit will enter the supply mode to introduce fresh air to dilute the CO₂ concentration until the CO₂ concentration is lower than the set value. The unit then returns to the previous mode. It can be set from 400 to 2000ppm.

12-hours timer.

Power ON/OFF.

Operating mode (supply mode, exhaust mode, regeneration mode).

CO₂ concentration function ON/OFF.

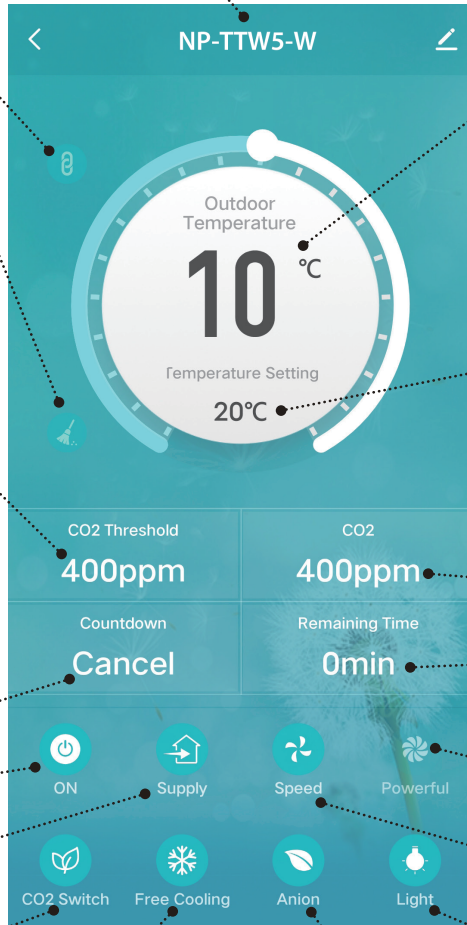

Outdoor temperature. It displays the outdoor temperature when the unit is ON and operating in supply or regeneration mode. In exhaust mode, the outdoor temperature is not sensed and displayed.

Free cooling temperature setting. When the outdoor air is comfortable, it will work in supply mode to introduce fresh air without heat recovery, it's called free cooling. Users can set the outdoor temperature to enable this function. The setting range is 10°C to 29°C.

Real-time indoor CO₂ concentration.

Remaining time after the scheduled shutdown.

Fan boost function. The unit will supply/exhaust at the highest speed.

Fan speed, total 3 speeds.

Negative ion function ON/OFF.

Indicator lights ON/OFF.

Humidity Version (Optional)

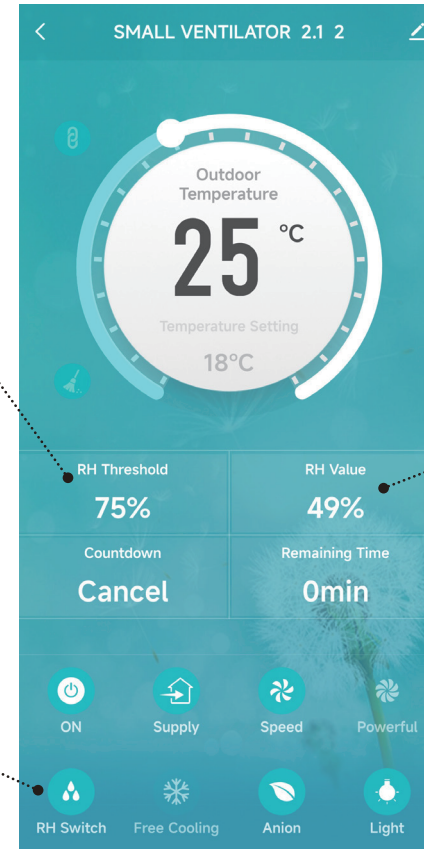

* Humidity setting: Under regeneration mode, when the indoor humidity level exceeds the set value, the unit will be switched to Exhaust mode to extract the indoor air for reducing the indoor humidity. The unit returns to the previous operation mode when the indoor humidity < set humidity - 5%, humidity setting range: 40-95%.

* Real-time indoor RH concentration.

* Humidity function ON/OFF.

► APP DOWNLOAD INSTRUCTIONS

Scan the QR code on the right to download the app, or search "smart life" in the Apple store and Google play store to install the app, download, and install using the device's WIFI connection. It's available for the mobile app to control the device and support Google and Alexa Smart speaker control function.



► IOT NETWORKING OPERATION STEPS

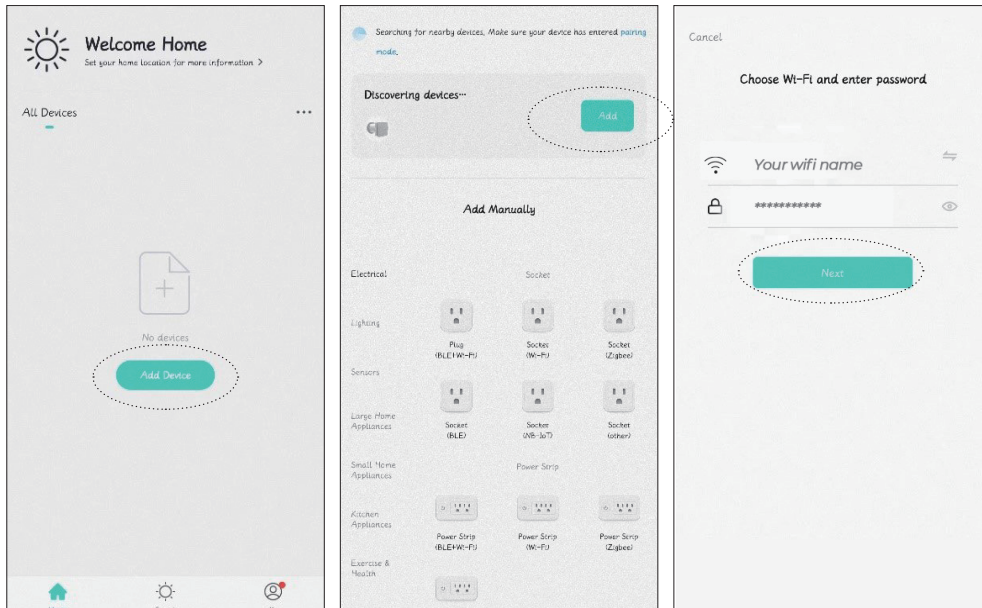

1. Before enabling Lot networking operation, please connect your cell phone to your home router WIFI, turn on the Bluetooth function of your cell phone, and ensure that the device and cell phone are within the WIFI signal coverage (make sure the router WIFI is enabled for 2.4G network).

2. When the device is powered on, in the OFF state, long press the ON/OFF button of any device for 5 seconds, the device status indicator will flash red slowly, then the device will enter the WIFI distribution state, and the cell phone will be available for operation and connection.

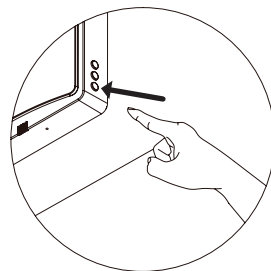

3. Open the downloaded Smart Vent app, enter the operation page, click the add device box, and search for devices.

4. At this time the app receives the signal from the device, then clicks to add the device for network connection.

► WIFI RESET AND CANCELLATION

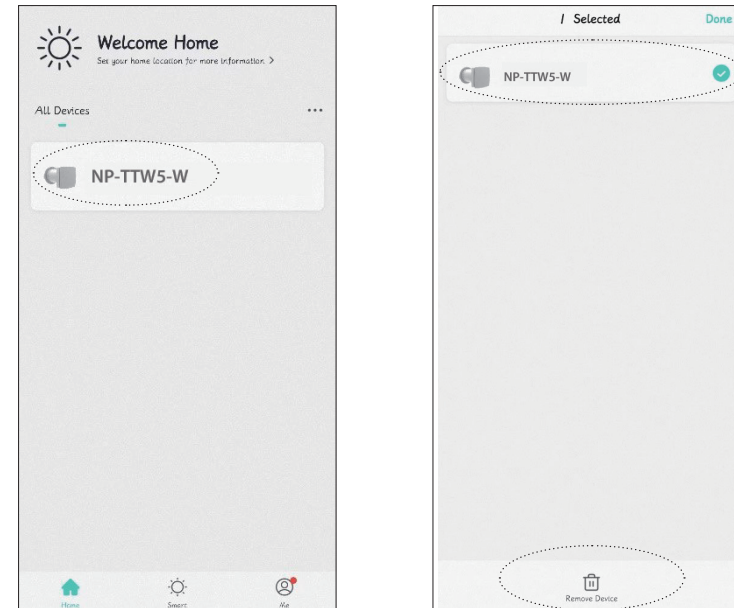

5. Click Add Device to find the WIFI signal of your home router, and make sure the WIFI name on the app is the same as the name of the WIFI connection to your phone, then log in with the WIFI password.

6. After successful WIFI connection, the device will be connected to the network, and after the connection is completed, you can enter the operation page to operate.

Remove the device from the app as follows:

1. Return to the app operation connection page, long press the device that needs to be disconnected, then the option to remove the device will appear at the bottom.
2. Click on the remove device option and confirm to successfully disconnect the device from the WIFI.

► MAINTENANCE

After unplugging the connecting wires of the main unit and the inner duct, remove the main unit and the inner duct from the wall separately.

Pull the rope at both sides of the ceramic energy regenerator and F7 medium filter and take off both F7 filter and ceramic energy regenerate from the inner duct.

- The ceramic energy regenerator should be cleaned at least 4 times a year.
- The F7 filter should be replaced regularly, it's recommended to change it after the filter alarm.

(The ceramic energy regenerator is fragile, it should be carefully pulled to avoid damage.)

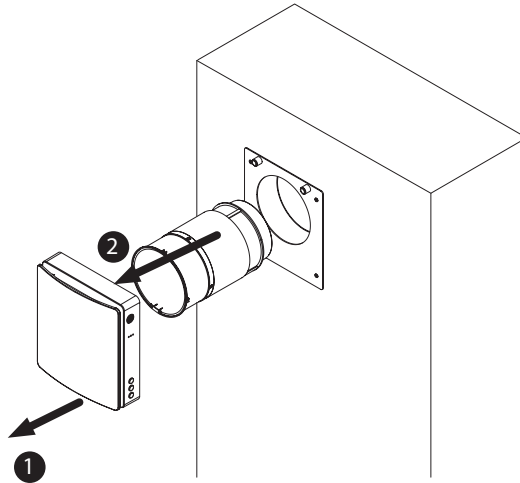

The F7 filter is not washable and should be vacuumed or replaced when dirty. Please contact the distributor to purchase the replacement filters

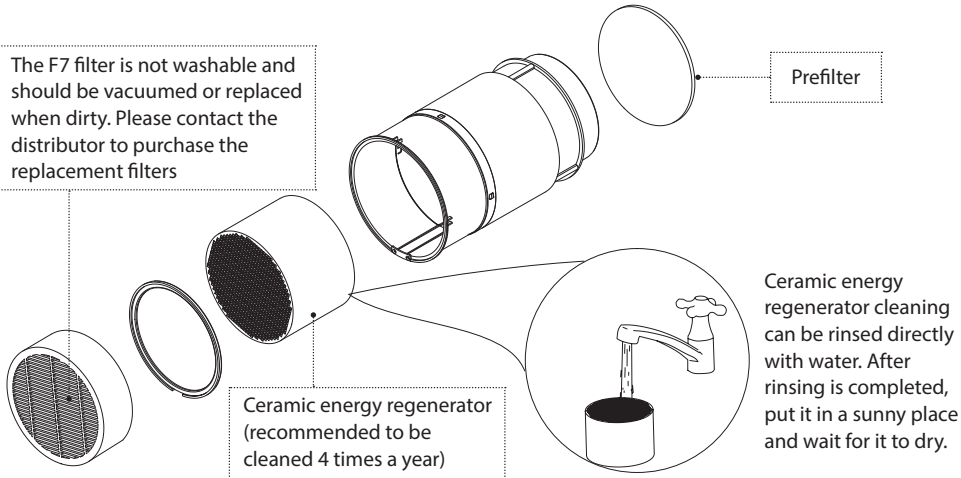

Ceramic energy regenerator cleaning can be rinsed directly with water. After rinsing is completed, put it in a sunny place and wait for it to dry.

Ceramic energy regenerator (recommended to be cleaned 4 times a year)



Even regular technical maintenance may not completely prevent dirt accumulation on the regenerator assemblies.
Subject the exchanger to regular cleaning to ensure high heat exchange efficiency.
Clean the exchanger with a vacuum cleaner at least once a year.



Clean the prefilter at least 4 times a year. The user can wash or vacuum the prefilter. Please note that after washing the prefilter, please dry it and reinstall it in the air duct. The lifetime of the prefilter is about 3 years. Please contact the distributor to purchase the replacement filters.

Fan Maintenance (Once Per Year).

Remove the fixed bracket in the inner duct and take out the fan.

Clean the impeller blades. Use a soft brush, doth, or a vacuum cleaner to clean the impeller. Do not use water abrasive detergents, solvents, or sharp objects. The impeller blades must be cleaned once a year.

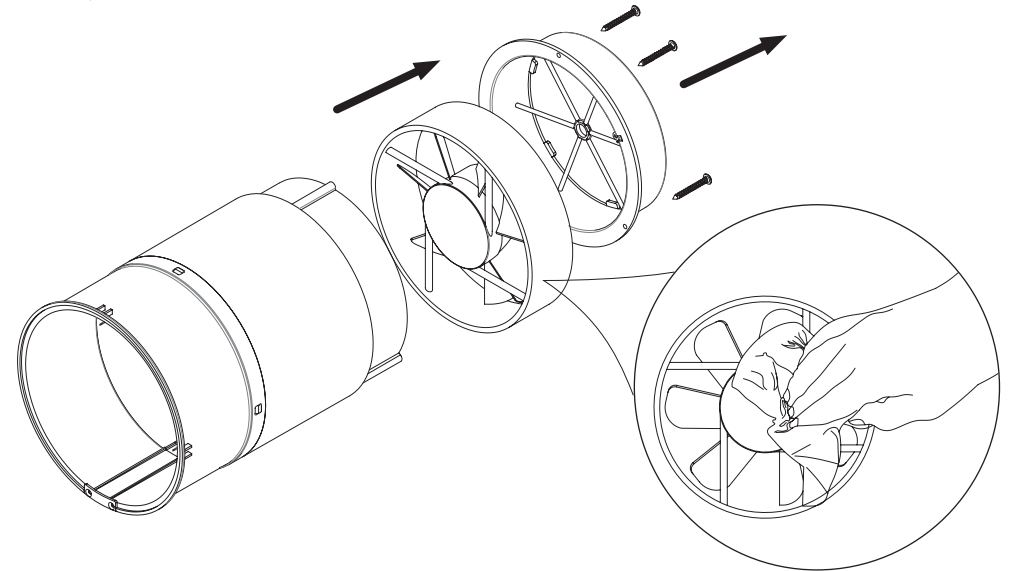

► STORAGE AND TRANSPORTATION RULES

Store the ventilator in the manufacturer's original packing box in a dry place.

The storage environment must be free of contain aggressive vapors and chemical mixtures that may cause corrosion, insulation, and sealing deformation. Use lifting equipment for handling and storage operations to prevent ventilator from damage as a consequence of failing or excessive vibration. Fulfill the handling requirements applicable for the applicable freight type.

Transportation by any type vehicle of allowed provided that the ventilator is protected against mechanical and weather damage.

Avoid any mechanical shocks and strokes during handling operations.

► TROUBLESHOOTING

Fault	Possible reasons	Troubleshooting
The fan does not Start up.	No power supply.	Make sure that the ventilator is properly connected to the power and make any corrections, if necessary.
	The motor is stuck, or the impellers are clogged.	Turn the ventilator off. Troubleshoot the motor jam and the impeller dogging. Clean the blades. Restart the ventilator.
Low airflow.	Low fan speed setting.	Set higher speed.
	Filter, fan, or exchanger are dirty.	Clean or replace the filter, and clean the fan and the exchanger. For exchanger and filter maintenance, see page 14.
Noise, vibration.	The impeller is dirty.	Clean the impeller.
	Loose screw Connection of the ventilator casing or the ventilation hood.	Tighten the screws of the ventilator or the outer hood.
Master-Slave pairing failed.	Master-Slave units set by a different controller.	According to the manual, use the same remote controller for the Master-Slave units settings.
	The ventilator is installed where is surrounded by a lot of metal/ there are sources of interference.	Excessive metal structures and interference sources around will weaken the wireless signal, please remove these sources of interference or change the installation location.
	The distance between Master and Slave units is too long/the wall between them is too thick.	Please change the installation location according to the distance specified in the manual.
	Other	Please reset the master-slave setting (press and hold the RESET button for ten seconds), and set it again after a period of power off.
WiFi connection failed.	The mobile phone is connected to the WiFi 5G network.	Please switch to the 2.4G frequency/network to connect.
	Wrong connected to public WiFi (such as WiFi in shopping malls, hotels, etc. That need to be registered and logged in).	Please set up the WIFI router correctly.
	The router has not yet set up an account and password.	
	The router is set to a higher security level.	
	You have exceeded the limit of devices that can be connected to the router.	
	Bluetooth on the mobile phone is off.	Enable Bluetooth on the mobile phone to improve the success rate of networking.